

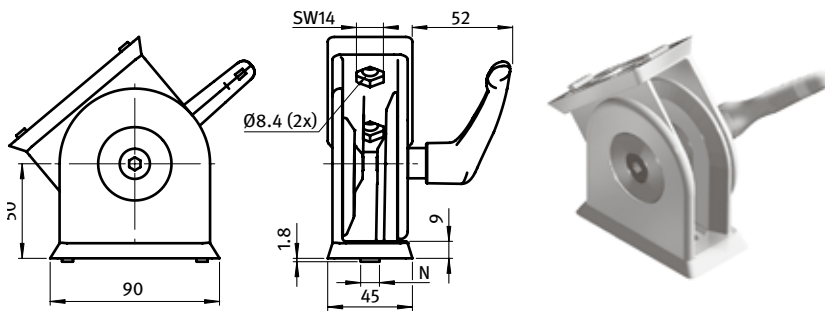

Gelenk 45 × 90 MIT KLEMMHEBEL

PIVOT JOINT 45 × 90 WITH LOCKING LEVER

<p>Ausführung Zinkdruckguss</p> <p>Beschreibung zur Verbindung von zwei Profilen oder Flächenelementen, in beliebigen Winkeln fixierbar, mit separaten Nutfixierungen für Nut 8 und Nut 10; mittels der Schrauben und des M_{Klemm}-Klemmhebels kann der Reibungswiderstand des Gelenkes stufenlos reguliert, bzw. das Gelenk in einer definierten Position fixiert werden</p> <p>Material Gelenk: Zinkdruckguss M_{Klemm}-Klemmhebel: Zinkdruckguss</p> <p>Liefereinheit 10 Stück</p> <p>Extras weitere Oberflächen, weitere Farben auf Anfrage</p> <p>Hinweis Schneidhülse zur Reduzierung des Kernlochs $\varnothing 10,2$ mm auf Gewindegröße M8 siehe Seite 500</p>	<p>Model Zinc die-cast</p> <p>Description To make a pivoting connection between two profiles or panels which can be fixed at any angle; with separate locating pins for slot 8 and 10; by tightening or loosening the screws and the M_{Klemm}-locking lever you can seamlessly regulate the functionality of the joint or you can fix it in one position</p> <p>Material Joint: Zinc die-cast M_{Klemm}-locking lever: Zinc die-cast</p> <p>Pack Quantity 10 pieces</p> <p>Specials Other surfaces, other colors on request</p> <p>Tip Cut bush for the reduction of the $\varnothing 10.2$ mm core hole to thread size M8 see page 500</p>
---	---



Gelenk 45 × 90 mit Klemmhebel <i>Pivot Joint 45 × 90 with Locking Lever</i>	N	Öffnungswinkel <i>Opening Angle</i>	Gewicht [g] <i>Weight [g]</i>	Teil-Nr. <i>Part #</i>
	- / 8 / 10	184°	1069.0	093GF4590AN

