

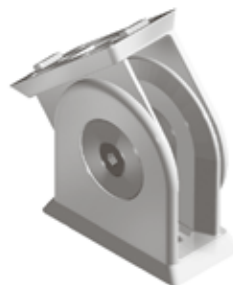

GELENK 45 x 90

PIVOT JOINT 45 x 90

<p>Ausführung mit einstellbarer Friktion, Zinkdruckguss</p> <p>Beschreibung zur beweglichen Verbindung von zwei Profilen oder Flächenelementen, mit separaten Nutfixierungen für Nut 8 und Nut 10; mittels der Schrauben kann der Reibungswiderstand des Gelenkes stufenlos reguliert, bzw. das Gelenk in einer definierten Position fixiert werden</p> <p>Material Zinkdruckguss</p> <p>Liefereinheit 10 Stück</p> <p>Extras weitere Oberflächen, weitere Farben auf Anfrage</p> <p>Hinweis Schneidhülse zur Reduzierung des Kernlochs Ø10,2 mm auf Gewindegröße M8 siehe Seite 500</p>	<p>Model With adjustable friction, zinc die-cast</p> <p>Description To make a pivoting connection between two profiles or panels; with separate locating pins for slot 8 and 10; by tightening or loosening the screws you can seamlessly regulate the functionality of the joint or you can fix it in one position</p> <p>Material Zinc die-cast</p> <p>Pack Quantity 10 pieces</p> <p>Specials Other surfaces, other colors on request</p> <p>Tip Cut bush for the reduction of the Ø 10.2 mm core hole to thread size M8 see page 500</p>
--	--

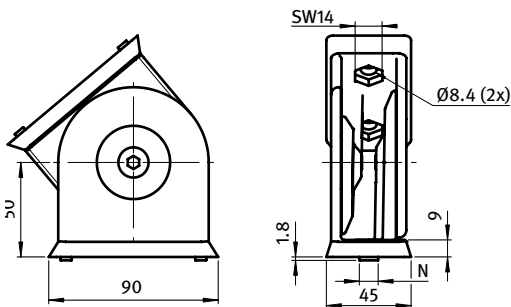

Gelenk 45 x 90 Pivot Joint 45 x 90	N	Öffnungswinkel Opening Angle	Gewicht [g] Weight [g]	Teil-Nr. Part #
	- / 8 / 10	184°	1046.0	093G4590AN

