

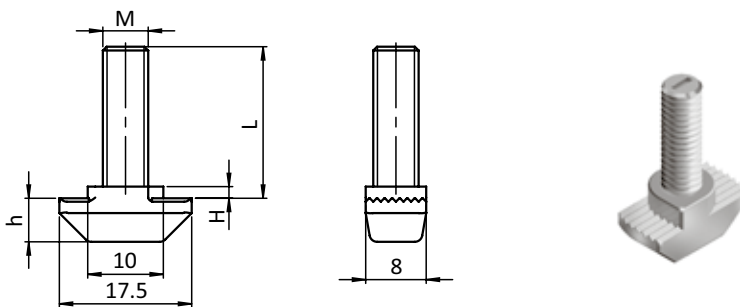

HAMMERSCHRAUBE

HAMMER HEAD SCREW

Ausführung	Nut 10, Stahl	Model	Slot 10, steel
Beschreibung	Befestigungselement für Aluminiumprofile, bricht die Eloxalschicht auf und schafft eine sichere, elektrisch leitfähige Verbindung	Description	To fasten components to profiles, breaks the anodized coat of the profile - thus ensuring a safe, electrically conductive connection
Material	Stahl, verzinkt	Material	Zinc plated steel
Liefereinheit	100 Stück	Pack Quantity	100 pieces
Extras	Drehhilfe: Polyamid-Fleckbeschichtung auf Anfrage Oberfläche: mit Trocken-Gleitfilm, Zink-Nickel- oder Zink-Lamellen-Überzug auf Anfrage	Specials	Turning help: Polyamide thread locking dot on request Surface: With dry film lubrication, zinc-nickel plated or with zinc lamellar plating on request
Hinweis	passende Flanschmutter siehe Seite 301 * bestehend aus Hammermutter mit geklebtem Gewindestück	Tip	Compatible flange nut see page 301 *Made of hammer nut with glued threaded rod



Hammerschraube Hammer Head Screw	B [mm]	H [mm]	Größe M x L [mm] Size M x L [mm]	Gewicht [g] Weight [g]	Profil Profile	Teil-Nr. Part #
	9.7	1.5	*M6 x 20	10.2		096HK1015M0620
	9.7	1.5	*M6 x 25	11.0		096HK1015M0625
	9.7	1.5	*M6 x 30	11.8		096HK1015M0630
	9.7	1.5	*M6 x 40	13.4		096HK1015M0640
	9.7	1.5	*M6 x 60	16.6		096HK1015M0660
	8.0	1.5	M8 x 20	12.7		096HK1015M0820
	8.0	1.5	M8 x 25	14.2		096HK1015M0825
	9.7	1.5	*M8 x 30	15.7		096HK1015M0830
	9.7	1.5	*M8 x 40	18.8		096HK1015M0840
	9.7	1.5	*M8 x 60	24.9		096HK1015M0860
	9.7	3.0	*M6 x 20	11.2	B	096HK1030M0620
	9.7	3.0	*M6 x 25	12.0	B	096HK1030M0625
	9.7	3.0	*M6 x 30	12.8	B	096HK1030M0630
	9.7	3.0	*M6 x 40	14.4	B	096HK1030M0640
	9.7	3.0	*M6 x 60	17.6	B	096HK1030M0660
	8.5	3.0	M8 x 20	13.3	B	096HK1030M0820
	8.5	3.0	M8 x 25	14.8	B	096HK1030M0825
	8.5	3.0	M8 x 30	16.3	B	096HK1030M0830
	8.5	3.0	M8 x 40	19.4	B	096HK1030M0840
	8.5	3.0	M8 x 60	25.5	B	096HK1030M0860
	8.5	4.5	M8 x 20	14.2	B	096HK1045M0820
	8.5	4.5	M8 x 25	14.4	B	096HK1045M0825
	8.5	4.5	M8 x 30	14.6	B	096HK1045M0830